

ASSEMBLY

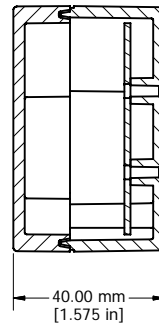

SECTION A-A

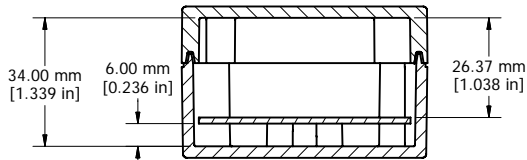
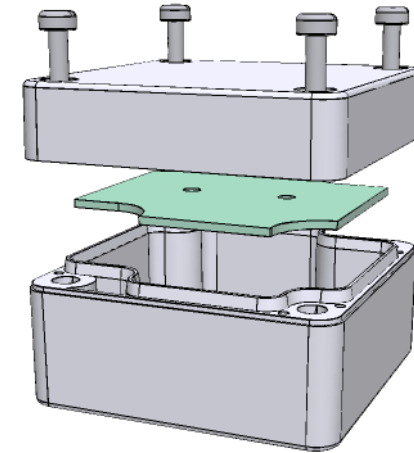

SECTION B-B

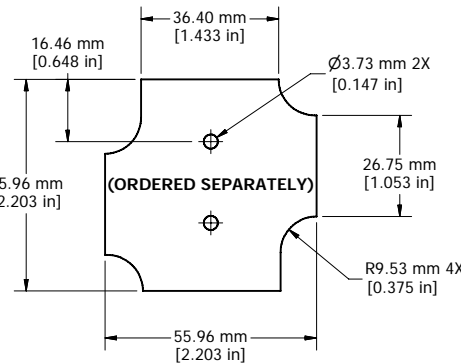

STEEL INNER PANEL



File #E65324  
NEMA 4, 4X

Enclosures can be Factory Modified ( Milling, Drilling, Printing etc. )  
Solid models of this enclosure available in STEP or IGES.  
Contact Factory [mjm@hammondmfg.com](mailto:mjm@hammondmfg.com)

NOTE	
Purchased assembly includes box, lid, and 4 cover screws	
Recommended Cover screw torque - 2.5 lbf-in (30 cN-m)	
Polycarbonate version is UL 508 approved Matl UL94 - V0 / 5VA @ 3mm	

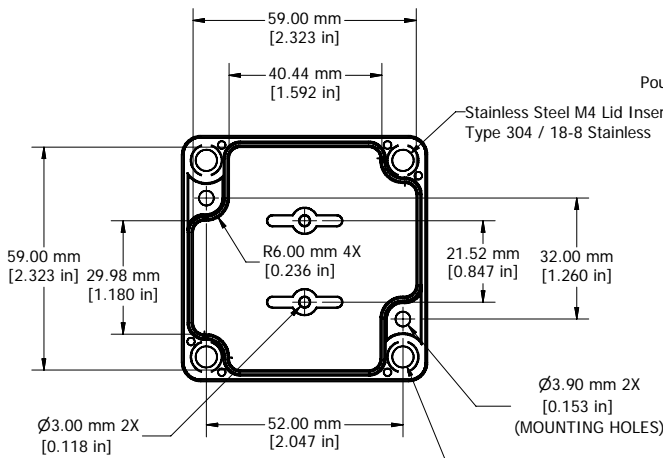

BOX - INSIDE

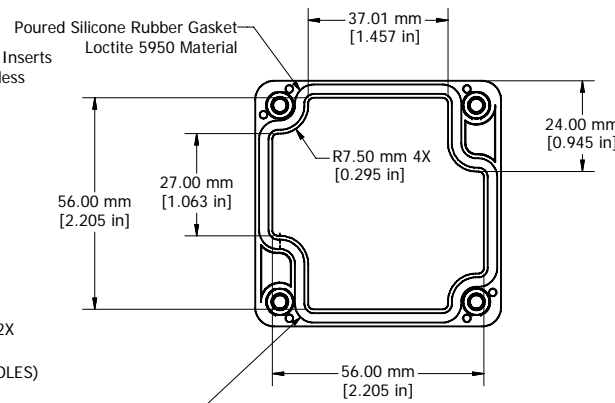

LID - INSIDE

1554B	
<b>1554B Regular Enclosure</b>	
General Purpose ABS RAL-7035	1554BGY
Polycarbonate RAL-7035	1554B2GY
<b>1554B Clear / Smoke Lid Enclosure</b>	
Polycarbonate Box / Clear Polycarbonate Lid	1554B2GYCL
Polycarbonate Box / Smoke Polycarbonate Lid	1554B2GYCL
<b>ACCESSORIES</b>	
Heavy Duty 16 Gauge Galvanized Steel Panels	1554BPL
Steel Panel / P.C. Board Machine Screw [M3 x 8mm Nickel plated]	1591MM100
Steel Panel / P.C. Board Self Tapping Screw [#6 X 1/4" (6.4mm) Nickel Plated]	1598ATS100
Cover Screws (Pkg 4) [M4 X 20mm Type 304 Stainless Steel]	SC1554



HAMMOND  
MANUFACTURING™

1554B

[www.hammondmfg.com](http://www.hammondmfg.com)